

HALL LED ESSENTIAL Large

IP54 protection from the bottom

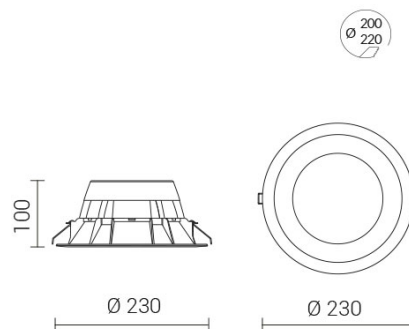
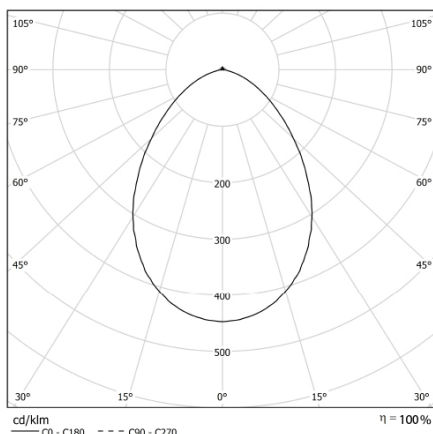

CODE		FLUX	SIZE	CERTIFICATIONS
38MP14K4L54	14W 4000K	2100lm	230mm	   

Optics

Microcell polycarbonate internal reflector and opal microprism polycarbonate diffuser. UGR<19.

Specifications

SMD LED technology;
Driver included;
CRI>90;
Mac Adams 3;
Life Time: L80/B10 >50.000h;
5 years complete warranty;
Eye safety: RG0/RG1 in accordance with EN62471:2009

Body

Polycarbonate body and die-cast aluminum heat sink.

Legal references

In compliance with the safety standards EN 60 598-1 and UNI EN 12464-1 (lighting for working places).

Wiring

RE: Built-in wiring 230-240V/50-60Hz with power factor >0.97.